

Onan *Mobile GenSet*

Operator's Manual

HDKAJ, HDKAK, HDKAT, HDKAU



Printed in U.S.A.

981-0161B
08-05

Supplement 981-1053

Date: 08-05

Insert with: Operator's Manual **981-0161** (8-99)
Installation Manual **981-0623** (8-99)

This Supplement adds Model **HDKAU** to the generator set models covered by the operator's and installation manuals in which it is inserted. Page 2 of this Supplement is an updated Specifications page which includes the new generator set model.

Write a note in the manual under the heading, **ABOUT THIS MANUAL**, and also on the *Specifications* page, to refer to the Supplement for Specifications on Model **HDKAU**.



Specifications

	Model HDKAJ / HDKAT	Model HDKAK / HDKAU
GENSET CONTROLLER: Integrated Microprocessor Based Engine and Generator Controller		
GENERATOR: Brushless, Exciterless, Bearingless, Permanent Magnet Alternator		
AC OUTPUT RATINGS:		
Power (@1.0 power factor)	7500 W	8000 W
Voltage	120 volts	120 volts
Frequency	60 Hz	60 Hz
Number of Phases	1	1
Current	62.5 ampere	66.7 ampere
Line Circuit Breaker(s)	One 2-pole, 30 or 35 amp	One 2-pole, 30 or 35 amp
ENGINE: 3-Cylinder In-Line, Water-Cooled, Indirect-Injection, 4-Stroke Cycle Diesel		
Bore	2.64 inch (67 mm)	
Stroke	2.68 inch (68 mm)	
Displacement	44 inch ³ (719 cc)	
Compression Ratio	23 : 1	
Oil Capacity (with filter)*	3 quart (2.6 l)	
Cooling System Capacity**	4.2 quart (4 l)	
Intake and Exhaust Valve Lash (Cold)	0.0065 inch (0.165 mm)	
OPERATING SPEED RANGE:	1600 to 3200 RPM (HDKAJ) 2300 to 3200 RPM (HDKAT)	1600 to 3300 RPM
FUEL CONSUMPTION:		
No-load	.13 gph (.49 l/h)	.13 gph (.49 l/h)
Half-load (4000 W)	.49 gph (1.85 l/h)	.49 gph (1.85 l/h)
Full-load	.96 gph (3.63 l/h)	1.02 gph (3.86 l/h)
DC SYSTEM:		
Nominal Battery Voltage	12 volts	
Minimum Battery Capacity	450 CCA*** down to 0° F (-17° C) 650 CCA*** down to -20° F (-29° C)	
Maximum Regulated-Voltage Battery Charging Current (Optional)	10 ampere	
Fuse F1 (control circuit)	10 ampere mini-bayonet	
Fuse F2 (starter solenoid circuit)	10 ampere mini-bayonet	
Fuse F3 (glow plug circuit)	25 ampere	
WEIGHT AND SIZE:		
Weight (wet)	420 lbs (191 kg)	
Length x Width x Height	36.3 x 23.6 x 22.3 inch (922 x 599 x 566 mm)	
* See oil filling instructions.		
** Includes coolant recovery tank.		
*** Cold Cranking Amps @ 0° F (-17° C)		

California

Proposition 65 Warning

Diesel engine exhaust and some of its constituents are known to the State of California to cause cancer, birth defects, and other reproductive harm.

 **WARNING** 

**Do not use this genset on a boat
Such use may violate U. S. Coast Guard
regulations and can result in
severe personal injury or death from
fire, electrocution, or
carbon monoxide poisoning**

Table of Contents

SAFETY PRECAUTIONS	2
INTRODUCTION	4
About this Manual	4
Model Identification	4
Typical Genset	5
Fuel Recommendations	6
Engine Oil Recommendations	6
Starting Batteries	6
Operator's Console	7
Remote Control Panel	7
OPERATION	8
Conducting the Pre-Start Checks	8
Priming the Fuel System	8
Starting the Genset	8
Stopping the Genset	9
Restarting the Genset	9
Loading the Genset	9
Resetting Circuit Breakers	10
Connecting to Utility Power	10
Operating in Cold Weather	11
Operating in Hot Weather	11
Operating at High Altitude	11
Operating in Dusty Environments	11
Breaking in a New Engine	11
Exercising the Genset	11
Storing the Genset	12
PERIODIC MAINTENANCE	13
Conducting General Inspections	14
Checking Engine Oil Level	15
Changing Engine Oil and Oil Filter	16
Maintaining the Battery and Battery Connections	17
Replacing the Air Filter Element	17
Cleaning the Spark Arrestor	18
Replacing the Fuel Filter	19
Changing Coolant	20
TROUBLESHOOTING	22
SPECIFICATIONS	31
INFORMATION FOR CALIFORNIA GENSET USERS	32
HOW TO OBTAIN SERVICE	33
MAINTENANCE RECORD	34

Safety Precautions

Thoroughly read the **OPERATOR'S MANUAL** before operating the genset. Safe operation and top performance can only be obtained when equipment is operated and maintained properly.

The following symbols in this manual alert you to potential hazards to the operator, service person and equipment.

⚠ DANGER alerts you to an immediate hazard which will result in severe personal injury or death.

⚠ WARNING alerts you to a hazard or unsafe practice which can result in severe personal injury or death.

⚠ CAUTION alerts you to a hazard or unsafe practice which can result in personal injury or equipment damage.

Electricity, fuel, exhaust, moving parts and batteries present hazards which can result in severe personal injury or death.

GENERAL PRECAUTIONS

- Keep ABC fire extinguishers handy.
- Make sure all fasteners are secure and torqued properly.
- Keep the genset and its compartment clean. Excess oil and oily rags can catch fire. Dirt and gear stowed in the compartment can restrict cooling air.
- Let the engine cool down before removing the coolant pressure cap or opening the coolant drain. Hot coolant under pressure can spray out and cause severe burns.
- Before working on the genset, disconnect the negative (–) battery cable at the battery to prevent starting.
- Use caution when making adjustments while the genset is running—hot, moving or electrically live parts can cause severe personal injury or death.

- Used engine oil has been identified by some state and federal agencies as causing cancer or reproductive toxicity. Do not ingest, inhale, or contact used oil or its vapors.
- Benzene and lead in some gasolines have been identified by some state and federal agencies as causing cancer or reproductive toxicity. Do not ingest, inhale or contact gasoline or its vapors.
- Do not work on the genset when mentally or physically fatigued or after consuming alcohol or drugs.
- Carefully follow all applicable local, state and federal codes.

GENERATOR VOLTAGE IS DEADLY!

- Generator output connections must be made by a qualified electrician in accordance with applicable codes.
- The genset must not be connected to the public utility or any other source of electrical power. Connection could lead to electrocution of utility personnel and damage to equipment. An approved switching device must be used to prevent interconnections.
- Use caution when working on live electrical equipment. Remove jewelry, make sure clothing and shoes are dry and stand on a dry wooden platform.

ENGINE EXHAUST IS DEADLY!

- Learn the symptoms of carbon monoxide poisoning in this manual and never sleep in the vehicle while the genset is running unless the vehicle is equipped with a working carbon monoxide detector.
- The exhaust system must be installed in accordance with the genset Installation Manual. Engine cooling air must not be used for heating the working or living space or compartment.
- Inspect for exhaust leaks at every startup and after every eight hours of running.
- Make sure there is ample fresh air when operating the genset in a confined area.

FUEL IS FLAMMABLE AND EXPLOSIVE

- Do not smoke or turn electrical switches ON or OFF where fuel fumes are present or in areas sharing ventilation with fuel tanks or equipment. Keep flame, sparks, pilot lights, arc-producing equipment and all other sources of ignition well away.
- Fuel lines must be secured, free of leaks and separated or shielded from electrical wiring.

BATTERY GAS IS EXPLOSIVE

- Wear safety glasses and do not smoke while servicing batteries.
- When disconnecting or reconnecting battery cables, always disconnect the negative (-) battery cable first and reconnect it last to reduce arcing.

MOVING PARTS CAN CAUSE SEVERE PERSONAL INJURY OR DEATH

- Do not wear loose clothing or jewelry near moving parts such as PTO shafts, fans, belts and pulleys.

- Keep hands away from moving parts.
- Keep guards in place over fans, belts, pulleys, etc.

DO NOT OPERATE IN FLAMMABLE AND EXPLOSIVE ENVIRONMENTS

Flammable vapor can cause a diesel engine to overspeed and become difficult to stop, resulting in possible fire, explosion, severe personal injury and death. ***Do not operate a diesel-powered genset where a flammable vapor environment can be created by fuel spill, leak, etc., unless the genset is equipped with an automatic safety device to block the air intake and stop the engine.*** The owners and operators of the genset are solely responsible for operating the genset safely. Contact your authorized Onan/Cummins dealer or distributor for more information.

Introduction

ABOUT THIS MANUAL

This manual covers the operation and maintenance of the HDKAJ, HDKAK, HDKAT and HDKAU Series of generator sets (gensets). Study this manual carefully and observe all of its instructions and precautions. Keep this manual and the genset Installation Manual with the other vehicle manuals.

Operation, Periodic Maintenance and Troubleshooting provide the instructions necessary for operating the genset and maintaining it at top performance. The owner is responsible for performing maintenance in accordance with the PERIODIC MAINTENANCE SCHEDULE (Page 13). This manual also includes genset specifications, information on how to obtain service and information for California users.

⚠ WARNING *This genset is not a life support system. It can stop without warning. Children, persons with physical or mental limitations, and pets could suffer personal injury or death. A personal attendant, redundant power or an alarm system must be used if genset operation is critical.*

MODEL IDENTIFICATION

When contacting an Onan dealer for parts, service or product information, be ready to provide the model and serial numbers on the genset nameplate. Figure 1 illustrates the nameplate and its location. The numbers in the gray boxes are typical model and serial numbers. Every character in these numbers is significant. (The last character of the model number is the specification letter, which is important for obtaining the right parts.) Record the model and serial numbers in the boxes in Figure 1 so that they are easy to find when you need them.

IMPORTANT ENGINE INFORMATION		
CUMMINS POWER GENERATION		
1400 73rd Ave. NE Minneapolis, MN 55432		
Model No:	80HDKAK11454J	Made in U.S.A.
S/N:	F990 123456	PH:
AC Volts:	kVA:	kW:
Amps:	Pf:	RPM:
Fuel:	Hz:	Bat:
Options:	Wiring Diagram:	
Insulation - NEMA Class F Ambient 40°C		
THIS ENGINE MEETS 1995-1999 CALIFORNIA EMISSION REGULATIONS FOR ULGE ENGINES		
SKB719U6D2RA		719 cc
REFER TO OPERATOR'S MANUAL FOR MAINTENANCE SPECIFICATIONS AND ADJUSTMENTS.		
99-2495 URC		

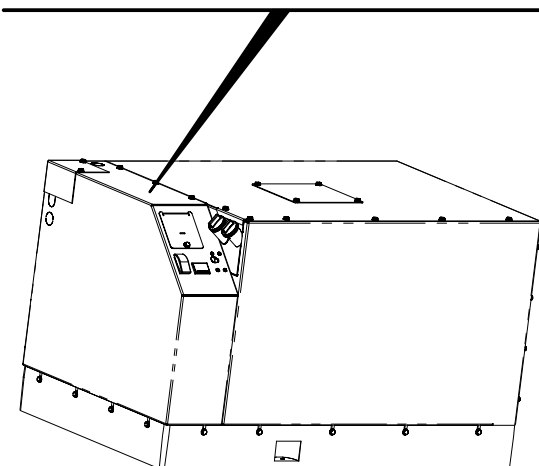

RECORD NUMBERS HERE

MODEL NUMBER:
SERIAL NUMBER:

FIGURE 1. TYPICAL NAMEPLATE

TYPICAL GENSET

The operator's console, the components requiring attention during periodic maintenance and other

features of a typical genset are shown in Figure 2. See the PERIODIC MAINTENANCE SCHEDULE (Page 13).

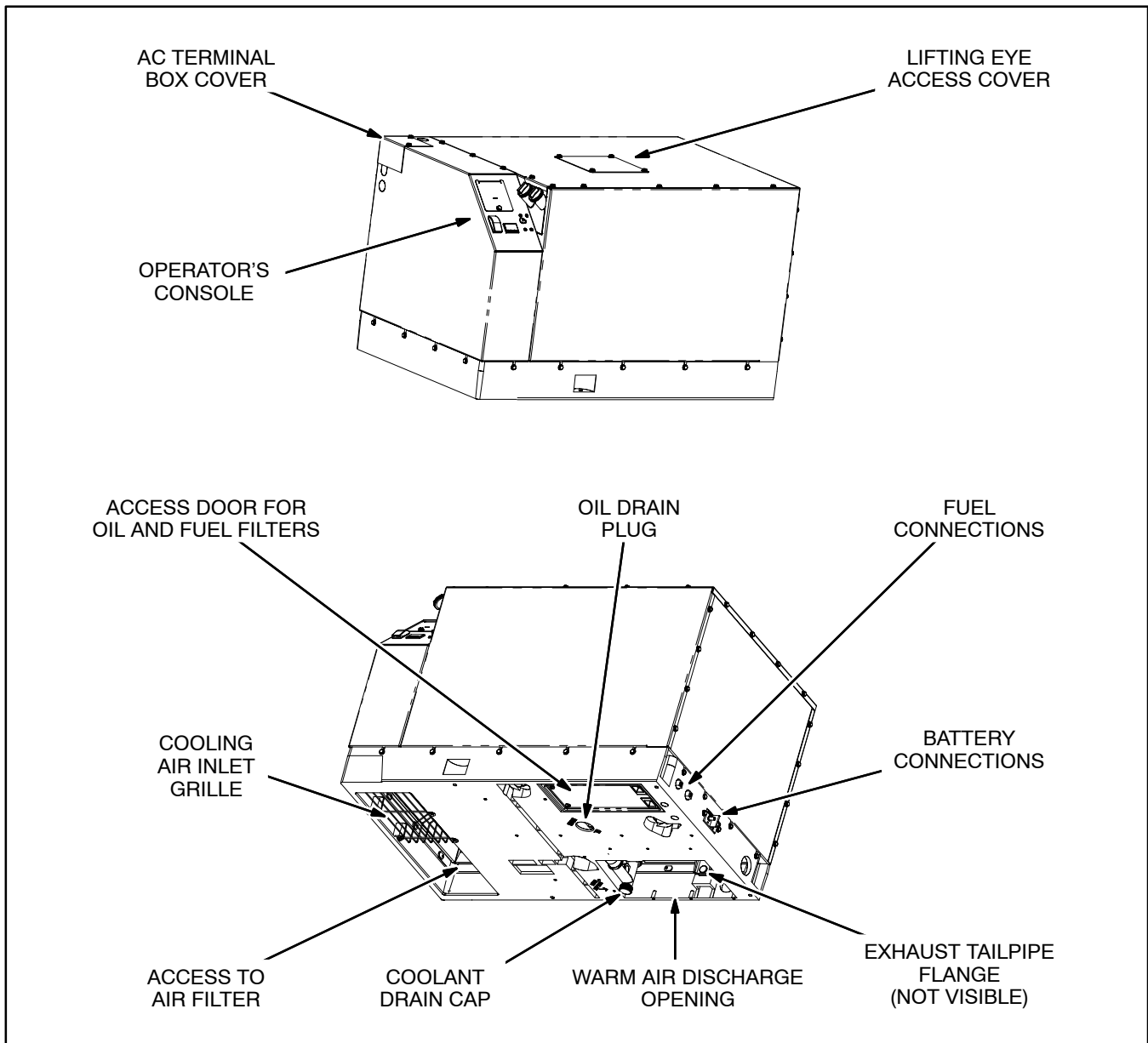

FIGURE 2. TYPICAL GENSET

FUEL RECOMMENDATIONS

⚠️WARNING *Diesel fuel is combustible and can cause severe personal injury or death. Do not smoke near diesel fuel tanks or equipment. Keep flames, sparks, pilot lights, electrical arcs, switches and arc-producing equipment and all other sources of ignition well away. Keep a type ABC fire extinguisher in the vehicle.*

Use clean, fresh No. 2 diesel fuel (ASTM 2-D) when the outdoor ambient temperature is above freezing, and No. 1 diesel fuel (ASTM 1-D) when below freezing. The fuel should have a Cetane number of at least 45 for reliable starting.

ENGINE OIL RECOMMENDATIONS

Use API (American Petroleum Institute) performance Class **CH-4**, **CG-4** or **CF-4** engine oil, which may be in combination with performance Class SJ, SH or SG (for example: CH-4/SJ). Also look for the

SAE (Society of Automotive Engineers) viscosity grade. Referring to Chart 1, choose the viscosity grade appropriate for the outdoor ambient temperatures expected until the next scheduled oil change.

STARTING BATTERIES

These gensets have a 12 volt, direct current (DC) starting and control system. See *Specifications* (Page 31) for minimum battery requirements (cold cranking amperes) for genset starting.

Regular, monthly maintenance of batteries may be required. See **MAINTAINING THE BATTERY AND BATTERY CONNECTIONS** (Page 17) and any instructions available from the vehicle manufacturer or battery manufacturer. Either the vehicle or the genset will be equipped with a battery charger.

Reliable genset starting and starter service life depend upon adequate battery system capacity and proper maintenance.

CHART 1. OIL VISCOSITY VS. TEMPERATURE

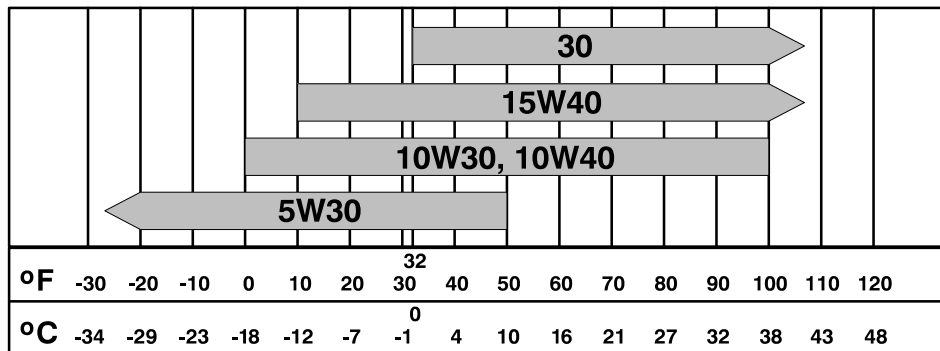

Anticipated Ambient Temperature

OPERATOR'S CONSOLE

The operator's console (Figure 3) has the following features:

Control Switch – This switch is used to start and stop the genset, prime the engine fuel system and restore the fault code (blinking status light).

Status Light – This is an LED (light emitting diode) in the control switch which blinks rapidly during preheat and cranking. (Preheat is the period of time prior to engine cranking when the glow plugs preheat the combustion chambers. The time is automatically varied by the genset controller on the basis of engine temperature.) After the genset starts up, this light stays on continuously, indicating that the genset is running and that the starter has disconnected. Also, if the genset shuts down, this light blinks in a coded fashion to indicate the nature of the shutdown (see *Troubleshooting*, Page 22).

Line Circuit Breaker(s) – The line circuit breaker(s) protect the AC power leads connected to the genset.

Engine Oil Fill Cap/Dipstick – The oil dipstick is attached to the fill cap and is marked ADD and FULL.

Coolant Recovery Tank Fill Cap – The recovery tank provides for coolant expansion. Replenish the normal loss of coolant by filling here.

Coolant Pressure Cap – The coolant pressure cap is accessible by removing the access plate on the control console. It provides for a pressurized engine cooling system. Fill coolant here when refilling the system.

Fuses F1, F2 and F3 – These fuses are accessible by removing the access plate on the control console. They protect the control circuits of the genset.

Hour Meter (Optional) – The hour meter records the total running time of the genset. It cannot be reset.

REMOTE CONTROL PANEL

The vehicle may be equipped with a remote control panel having a **Control Switch** and **Preheat/Diagnostics Light**. In addition, it may have an hour meter and the following engine gauges:

Oil Pressure Gauge – The oil pressure gauge indicates the presence of engine oil pressure.

Water Temperature Gauge – The water temperature gauge indicates engine coolant temperature.

Voltmeter – The voltmeter indicates battery voltage.

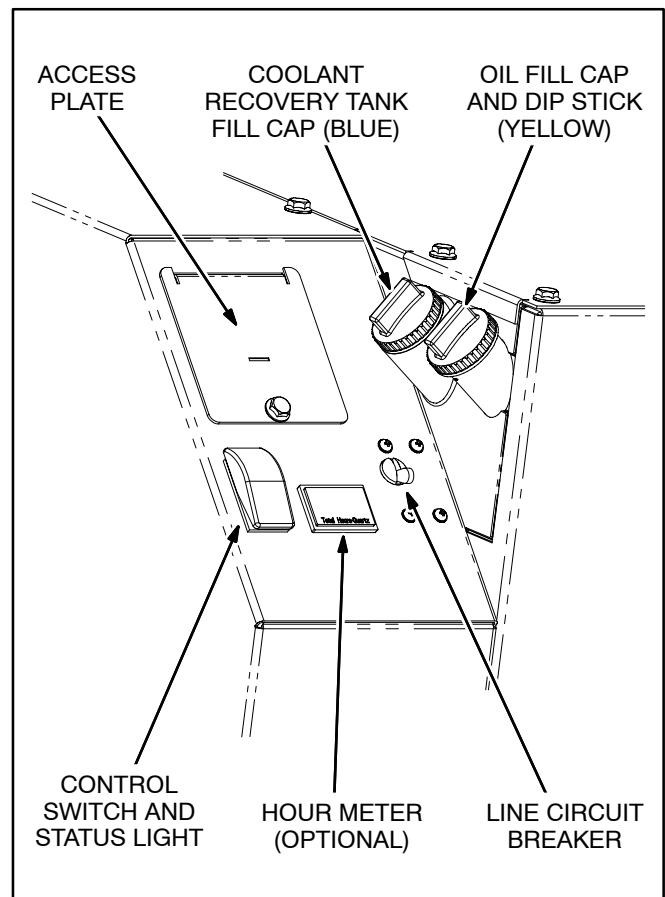

FIGURE 3. OPERATOR'S CONSOLE

Operation

⚠️WARNING EXHAUST GAS IS DEADLY!

Exhaust gases contain carbon monoxide, an odorless, colorless gas. Carbon monoxide is poisonous and can cause unconsciousness and death. Symptoms of carbon monoxide poisoning include:

- *Dizziness*
- *Throbbing in Temples*
- *Nausea*
- *Muscular Twitching*
- *Headache*
- *Vomiting*
- *Weakness and Sleepiness*
- *Inability to Think Clearly*

IF YOU OR ANYONE ELSE EXPERIENCES ANY OF THESE SYMPTOMS, GET OUT INTO THE FRESH AIR IMMEDIATELY. If symptoms persist, seek medical attention. Shut down the genset and do not operate it until it has been inspected and repaired.

Never sleep in the vehicle with the genset running unless the vehicle is equipped with a working carbon monoxide detector. Primary protection against poisoning due to inhaling carbon monoxide, however, consists of proper installation of the exhaust system and inspections every day (every eight hours of operation) for visible and audible exhaust system leaks.

CONDUCTING THE PRE-START CHECKS

Before the first start of the day and after every eight hours of operation, inspect the genset as instructed under CONDUCTING GENERAL INSPECTIONS (Page 14). Keep a log of maintenance and the hours run and perform any maintenance that may be due. See Returning the Genset to Service (Page 12) if the vehicle has been in storage.

Before each start:

1. Make sure all vehicle CO detectors are working.
2. Check for signs of fuel and exhaust leaks and for damage to the exhaust system.
3. Turn off the air conditioner and other large appliances.

PRIMING THE FUEL SYSTEM

The fuel system should be primed after replacing the fuel filter or running the genset out of fuel. To prime the fuel system hold the control switch down in its **Stop** position for at least 1 minute.

STARTING THE GENSET

Start the genset from the genset control panel or remote control panel inside the vehicle.

1. Push and hold the switch at **START** until the genset starts. The status indicator light on the switch flashes during preheat and cranking. It will come on solid when the starter disconnects, indicating that the genset is running. (Depending on how cold it is, preheat can take up to 15 seconds, extending the time that the light blinks.)

⚠️CAUTION *Excessive cranking can over-heat and damage the starter motor. Do not crank for more than 20 seconds at a time. Wait at least 2 minutes before trying again.*

2. See *Troubleshooting* (Page 22) if the genset does not start after three tries.
3. For top performance and engine life, especially in colder weather, let the engine warm up for two minutes before connecting appliances.
4. Monitor the engine gauges if the remote panel is so equipped. Normal readings during operation are as follows:

Oil Pressure: Approximate center of scale

Temperature: 160°-220° F (71°-104° C)

DC Voltage: 14-15 volts.

5. Check for fuel, exhaust and coolant leaks. Stop the genset immediately if there is a fuel, exhaust or coolant leak and have it repaired.

STOPPING THE GENSET

Turn off the air conditioner and other large appliances and let the genset run for two minutes to cool down. Then press the switch to **STOP** to stop the genset.

RESTARTING THE GENSET

See *Troubleshooting* (Page 22) if the genset shuts down abnormally.

LOADING THE GENSET

The genset can power AC motors, air conditioners, AC/DC converters, battery chargers and other appliances. How much appliance load* can be powered depends upon the genset power rating. The genset will shut down or its circuit breakers will trip if the sum of the loads exceeds genset power. (If the genset shuts down, the status light will probably display Fault Code No. 11, 13, 22 or 38. See *Troubleshooting*, Page 22.)

To avoid overloading the genset and causing shutdowns, compare the sum of the loads of the appliances that are likely to be used at the same time to the power rating of the genset. Use Table 1 or the ratings on the appliances themselves (if so marked) to obtain the individual appliance loads. ***It may be necessary to run fewer appliances at the same time—the sum of the loads must not be greater than genset rating.***

The genset may shut down due to overload when a large motor or air conditioner is started or cycles off and then on again, even though the sum of the loads is less than genset rating. The reason for this is that a motor's startup load is much larger than its running load. ***It may be necessary to run fewer appliances when large motors and air conditioners are cycling on and off.***

Maximum power decreases as altitude increases because air density decreases. For every 1000-foot (305 m) increase in elevation you can expect power to decrease approximately 3 percent. Table 2 shows the results of typical calculations. ***It may be necessary to run fewer appliances at higher altitudes.***

TABLE 1. TYPICAL APPLIANCE LOADS

Appliance	Load (watts)
Air Conditioner	1400-2000
Battery Charger	Up to 2000
DC Converter	300-1200
Refrigerator	600-1000
Microwave Oven	1000-1500
Electric Frying Pan or Wok	1000-1500
Electric Stove Element	350-1000
Electric Water Heater	1000-1500
Electric Iron	500-1200
Electric Hair Dryer	800-1500
Coffee Percolator	550-750
Television	200-600
Radio	50-200
Electric Drill	250-750
Electric Broom	200-500
Electric Blanket	50-200

TABLE 2. POWER VS. ALTITUDE

Elevation above Mean Sea Level	Max Genset Power*	Max Genset Power*
up to 500 ft (152 m)	7500 watts (rated)	8000 watts (rated)
2500 ft (762 m)	7050 watts	7520 watts
5500 ft (1676 m)	6375watts	6800watts
above 5500 ft (1676 m)	6375watts minus 225 watts every 1000 ft (305 m)	6800watts minus 240 watts every 1000 ft (305 m)
* This table does not take into account the effect circuit breakers may have in limiting maximum power.		

Commercial Applications (Model HDKAT and HDKAU)

Maximum genset power (nameplate rating) is 7500 watts in an ambient of 85° F (29° C), but only 6000 watts in an ambient of 120° F (50° C)—the maximum operating temperature. Also, continuous operation at up to 80 percent of maximum power (6000 watts) is acceptable.

* Appliance load and genset power are measured in terms of watts (W) or kilowatts (kW), where 1 kilowatt (kW) = 1000 watts (W).

RESETTING CIRCUIT BREAKERS

If a circuit breaker in the main power distribution panel of the vehicle or on the genset (Figure 4) trips, either a circuit shorted or too many appliances were running. Note that the genset will continue to run after a circuit breaker trips.

If a circuit breaker trips, disconnect or turn off as many loads as possible and reset the circuit breaker. (Push the circuit breaker to **OFF** to reset it and then to **ON** to reconnect the circuit.) If the circuit breaker trips right away, either the electrical distribution system has a short or the circuit breaker is faulty. Call a qualified electrician.

If the circuit breaker does not trip, reconnect the appliances, one by one, up to a total load that does not overload the genset or cause the circuit breaker to trip. If a circuit breaker trips right away when an appliance is connected, the appliance probably has a short.

Electrical appliances and tools must be used and maintained properly and be properly grounded to cause the line circuit breakers to trip when short circuits occur.

⚠WARNING *Short circuits in electrical appliances and tools can cause fire and electrical shock leading to severe personal injury or death. Read and follow the equipment and tool manufacturer's instructions and warnings regarding use, maintenance and proper grounding.*

CONNECTING TO UTILITY POWER

When the vehicle has provisions for connecting to utility power, such as a cord for plugging into a power outlet receptacle, it must also have an approved device to keep the genset and utility from being interconnected. See the genset Installation Manual for more information.

⚠WARNING *Interconnecting the genset and the public utility (or any other power source) can lead to the electrocution of personnel working on the utility lines, damage to equipment and fire. An approved switching device must be used to prevent interconnections.*

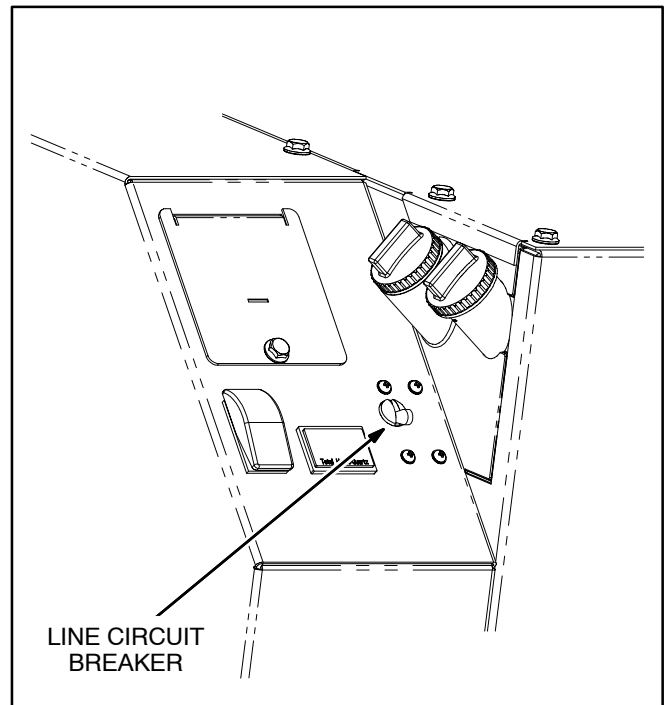

FIGURE 4. LINE CIRCUIT BREAKER

OPERATING IN COLD WEATHER

Make sure the engine oil viscosity is appropriate for the cold weather temperatures. See ENGINE OIL RECOMMENDATIONS (Page 6). Be sure to change the oil if a sudden drop in temperature occurs.

OPERATING IN HOT WEATHER

Pay particular attention to the following items when operating the genset in hot weather:

1. Make sure nothing blocks airflow to and from the genset.
2. Make sure engine oil viscosity is appropriate for the ambient temperatures. See ENGINE OIL RECOMMENDATIONS (Page 6).
3. Keep the genset clean.
4. Perform maintenance due. See PERIODIC MAINTENANCE SCHEDULE (Page 13).

OPERATING AT HIGH ALTITUDE

For the effect of altitude on maximum power, see LOADING THE GENSET (Page 9).

OPERATING IN DUSTY ENVIRONMENTS

Pay particular attention to the following items when operating the genset in dusty environments:

1. Do not let dirt and debris accumulate inside the genset compartment. Keep the genset clean.
2. Perform air cleaner maintenance more often. See PERIODIC MAINTENANCE SCHEDULE (Page 13).

3. Change engine oil more often. See PERIODIC MAINTENANCE SCHEDULE (Page 13).
4. Keep containers of engine oil that have been opened tightly closed to keep out dust.

BREAKING IN A NEW ENGINE

Proper engine break-in on a new genset or on one with a rebuilt engine is essential for top engine performance and acceptable oil consumption. Run the genset at approximately 1/2 rated power for the first 2 hours and then at 3/4 rated power for 2 more hours. See LOADING THE GENSET (Page 9).

Proper engine oil and oil level are especially critical during break-in because of the higher engine temperatures that can be expected. Change the oil if not appropriate for the ambient temperatures during break-in. See ENGINE OIL RECOMMENDATIONS (Page 6). Check oil level twice a day or every 4 hours during the first 24 hours of operation and change the oil and oil filter after the first 50 hours of operation.

EXERCISING THE GENSET

Exercise the genset at least 2 hours each month if use is infrequent. Run the genset at approximately 1/2 rated power. See LOADING THE GENSET (Page 9). A single two hour exercise period is better than several shorter periods.

Exercising a genset drives off moisture, re-lubricates the engine, replaces stale fuel and removes oxides from electrical contacts. The result is better starting, more reliable operation and longer engine life.

STORING THE GENSET

Proper storage is essential for preserving top genset performance and reliability when the genset cannot be exercised regularly and will be idle for more than 120 days.

Storing the Genset

1. Push the genset line circuit breaker OFF (Page 10).
2. Change the engine oil and attach a tag indicating oil viscosity. See ENGINE OIL RECOMMENDATIONS (Page 6).
3. Disconnect the battery cables (negative [-] cable first) from the starting battery and store the battery according to the battery manufacturer's recommendations. See MAINTAINING THE BATTERY AND BATTERY CONNECTIONS (Page 17).
4. Plug the exhaust tail pipe to keep out dirt, moisture, bugs, etc.

5. Close the fuel supply valve (if so equipped).

Returning the Genset to Service

1. Check the oil tag on the genset and change the oil if the viscosity indicated is not appropriate for the temperatures expected. See ENGINE OIL RECOMMENDATIONS (Page 6).
2. Reconnect the starting battery (negative [-] cable last). See MAINTAINING THE BATTERY AND BATTERY CONNECTIONS (Page 17).
3. Remove the plug from the exhaust tailpipe.
4. Change the air filter element if it is dirty (Page 17).
5. Open the fuel supply valve (if so equipped).
6. Inspect the genset. See CONDUCTING GENERAL INSPECTIONS (Page 14).
7. Push the genset line circuit breaker ON (Page 10) when the genset is ready to power appliances.

Periodic Maintenance

Periodic maintenance is essential for top performance and long genset life. Use Table 3 as a guide for normal periodic maintenance. In hot and dusty environments some maintenance procedures should be performed more frequently, as indicated by the footnotes in the table. Keeping a log of maintenance performed and hours run (Page 34) will

help you keep genset maintenance regular and provide a basis for supporting warranty claims.

Maintenance, replacement or repair of emission control devices and systems may be performed by any engine repair establishment or individual. However, warranty work must be completed by an authorized Onan dealer.

TABLE 3. PERIODIC MAINTENANCE SCHEDULE

MAINTENANCE PROCEDURE	MAINTENANCE FREQUENCY						Page
	Every Day	After First 50 Hours	Every Month	Every 150 Hours	Every 500 Hours	Every 1000 Hours	
General Inspection	X						14
Check Engine Oil Level	X						15
Check Engine Coolant Level	X						20
Clean and Check Battery			X ³				17
Change Engine Oil and Filter		X ¹		X ^{2, 3, 4}			16
Clean Spark Arrestor				X ⁴			18
Replace Engine Air Filter					X ^{2, 4}		17
Replace Fuel Filter					X		19
Check Coolant Anti-freeze Protection					X		20
Flush Coolant System						X ⁵	20
Replace Coolant Pressure Cap						X ⁵	20
Replace Engine V-belt						X ^{6,7}	–
Clean Crankcase Breather						X ^{6,7}	–
Replace Coolant Hoses and Thermostat						X ^{6, 7}	–

- 1 – As a part of engine break-in, change the engine oil after the first 50 hours of operation.
- 2 – Perform more often when operating in dusty conditions.
- 3 – Perform more often when operating in hot weather.
- 4 – Perform at least once a year.
- 5 – Perform at least once every two years.
- 6 – Perform at least once every five years.
- 7 – Must be performed by a qualified mechanic (authorized Onan dealer).

CONDUCTING GENERAL INSPECTIONS

Inspect the genset before the first start of the day and after every eight hours of operation.

Oil Level

Check engine oil level (Page 15).

Engine Coolant System

⚠ CAUTION *Operating the genset when coolant level is low can cause serious engine damage.*

Check the coolant level and look for coolant leaks around the bottom of the genset and on the ground below. Minor leaks that can be replenished by daily additions of coolant to the recovery tank should be repaired by a qualified service technician as soon as possible. Larger leaks are cause for shutting down the genset until it can be repaired.

Exhaust System

⚠ WARNING *EXHAUST GAS IS DEADLY! Do not operate the genset if there is an exhaust leak or any danger of exhaust gases entering or being drawn into the vehicle.*

Look and listen for exhaust system leaks while the genset is running. Shut down the genset if a leak is found and have it repaired before operating the genset again.

Look for openings or holes between the genset compartment and vehicle cab or living space if the genset engine sounds louder than usual. Have all such openings or holes closed off or sealed to prevent exhaust gases from entering the vehicle.

Replace dented, bent or severely rusted sections of the tailpipe and make sure the tailpipe extends at least 1 inch (25.4 mm) beyond the perimeter of the vehicle.

⚠ WARNING *Do not park the vehicle in high grass or brush. Contact with the exhaust system can cause a fire.*

Park the vehicle so that the genset exhaust gases can disperse away from the vehicle. Barriers such as walls, snow banks, high grass and brush and other vehicles can cause exhaust gases to accumulate in and around the vehicle.

Do not operate power ventilators or exhaust fans while the vehicle is standing with the genset running. The ventilator or fan can draw exhaust gases into the vehicle.

Fuel System

Check for leaks at hose, tube and pipe fittings in the fuel supply system while the genset is running and while it is stopped. Check flexible fuel hose sections for cuts, cracks, and abrasions. Make sure the fuel line is not rubbing against other parts. Replace worn or damaged fuel line parts before leaks occur.

⚠ WARNING *Diesel fuel leaks can lead to fire. Do not operate the genset if operation causes fuel to leak.*

Battery Connections

Check the battery terminals for clean, tight connections. Loose or corroded connections have high electrical resistance which makes starting harder. See MAINTAINING THE BATTERY AND BATTERY CONNECTIONS (Page 17).

⚠ WARNING *Arcing at battery terminals or in light switches or other equipment, and flames or sparks, can ignite battery gas causing severe personal injury.*

Ventilate battery area before working on or near battery—Wear safety glasses—Do not smoke—Switch trouble light ON or OFF away from battery—Stop genset and disconnect charger before disconnecting battery cables—Disconnect negative (–) cable first and reconnect last.

Mechanical

Look for mechanical damage. Start the genset and look and listen for any unusual noises and vibrations.

Check the genset mounting bolts to make sure they are secure.

Check to see that the genset air inlet and outlet openings are not clogged with debris or blocked.

Check the engine gauges from time to time while the genset is running (if so equipped).

CHECKING ENGINE OIL LEVEL

⚠ WARNING *State and federal agencies have determined that contact with used engine oil can cause cancer or reproductive toxicity. Try to avoid skin contact and breathing of vapors. Use rubber gloves and wash exposed skin.*

Park the vehicle on level ground and shut off the genset before checking the engine oil level.

1. Unscrew the oil fill cap, pull out the dipstick and wipe off the oil (Figure 5). Reinsert the dipstick, screw the cap back on, remove the dipstick again and check the oil level on the dip stick.
2. Add or drain oil as necessary. See ENGINE OIL RECOMMENDATIONS (Page 6). Keep the oil level between the FULL and ADD marks.

⚠ CAUTION *Too much oil can cause high oil consumption. Too little oil can cause severe engine damage. Keep the oil level between the FULL and ADD marks.*

3. Reinsert the dipstick and screw the oil fill cap back on securely.

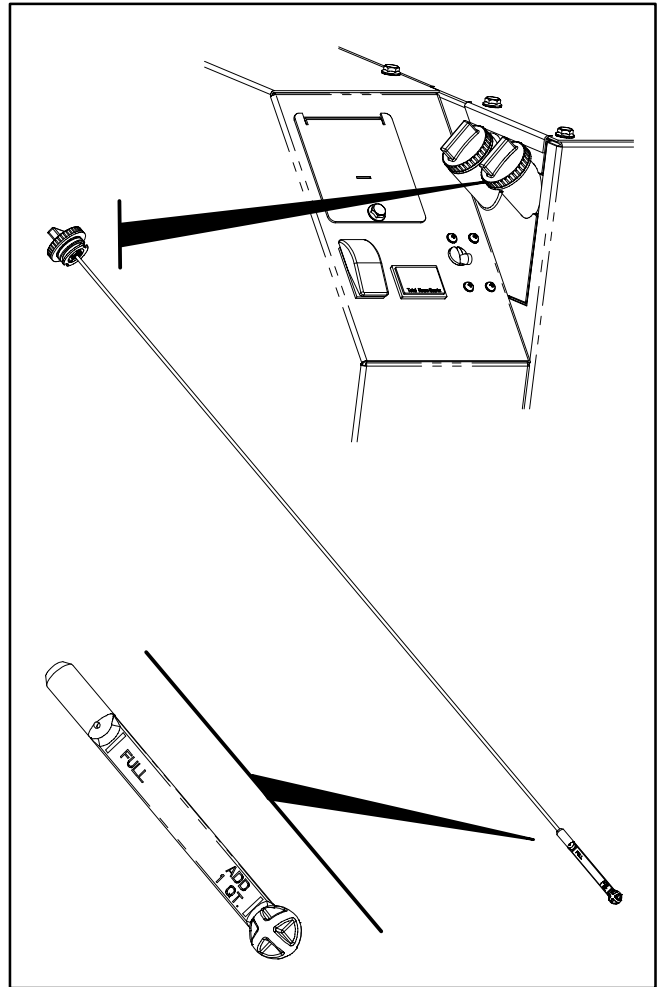

FIGURE 5. CHECKING ENGINE OIL LEVEL

CHANGING ENGINE OIL AND OIL FILTER

⚠ WARNING *State and federal agencies have determined that contact with used engine oil can cause cancer or reproductive toxicity. Avoid skin contact and breathing of vapors. Use rubber gloves and wash exposed skin.*

Refer to Table 3 for scheduled engine oil change. Change oil more often in hot and dusty environments.

1. Run the engine until warm, stop it and remove the oil fill cap and dipstick (Figure 5).
2. Place a pan underneath the genset and unscrew the oil drain plug (Figure 6). Let all oil drain from the engine.
3. Reinstall the oil drain plug and tighten it securely to prevent oil leakage.
4. Squeeze the access door latches together and let the door swing down (Figure 6).
5. Spin off the oil filter canister. Thoroughly wipe off the filter mounting surface and remove the

old gasket if it does not come off with the filter canister.

6. Make sure the new gasket is in place on the new filter canister and apply a thin film of oil to the gasket. (The replacement filter canister has a larger diameter than the original filter canister, but will fit.)
 7. Spin on the new filter canister by hand until the gasket just touches the mounting pad and then turn it an additional 1/2 to 3/4 turn. Do not over-tighten. Close the access door, making sure it latches securely.
 8. Refill with 3 quarts (2.6 l) of oil. See ENGINE OIL RECOMMENDATIONS (Page 6). Check the oil level and add or drain oil as necessary.
- ⚠ CAUTION** *Too much oil can cause high oil consumption. Too little oil can cause severe engine damage. Keep the oil level between the FULL and ADD marks.*
9. Reinsert the dipstick and screw the oil fill cap back on securely.
 10. Dispose of the used oil and oil filter in accordance with local environmental regulations.

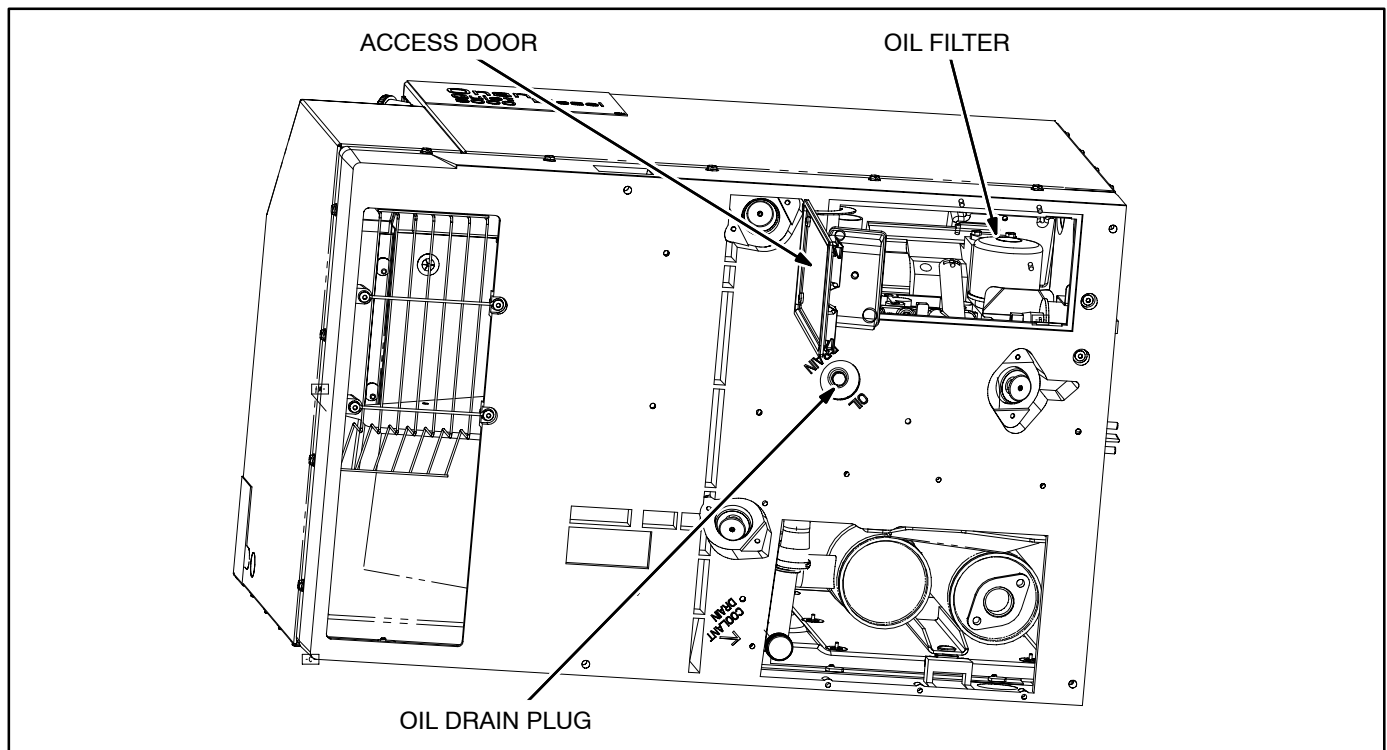

FIGURE 6. OIL DRAIN PLUG AND OIL FILTER

MAINTAINING THE BATTERY AND BATTERY CONNECTIONS

⚠WARNING Arcing at battery terminals or in light switches or other equipment, and flames or sparks, can ignite battery gas causing severe personal injury.

Ventilate battery area before working on or near battery—Wear safety glasses—Do not smoke—Switch trouble light ON or OFF away from battery—Stop genset and disconnect charger before disconnecting battery cables—Disconnect negative (–) cable first and reconnect last.

Refer to Table 3 for scheduled battery maintenance, and follow the battery manufacturer's instructions. Have the battery charging system serviced if DC system voltage is consistently low or high. Always:

1. Keep the battery case and terminals clean and dry and the terminals tight.

2. Remove battery cables with a battery terminal puller.
3. Make sure which terminal is positive (+) and which is negative (–) before making battery connections, always removing the negative (–) cable first and reconnecting it last to reduce arcing.

REPLACING THE AIR FILTER ELEMENT

Refer to Table 3 for scheduled air filter element replacement. In dusty environments the filter element should be inspected and changed more frequently. To change the filter element (Figure 7), remove the outer and inner cover and reassemble with a new air filter element. Turn the inner cover wingnut three to four clicks past seating. Make sure the outer cover is seated before tightening its wingnut. **Check for noise when the genset is running, and retighten if necessary.**

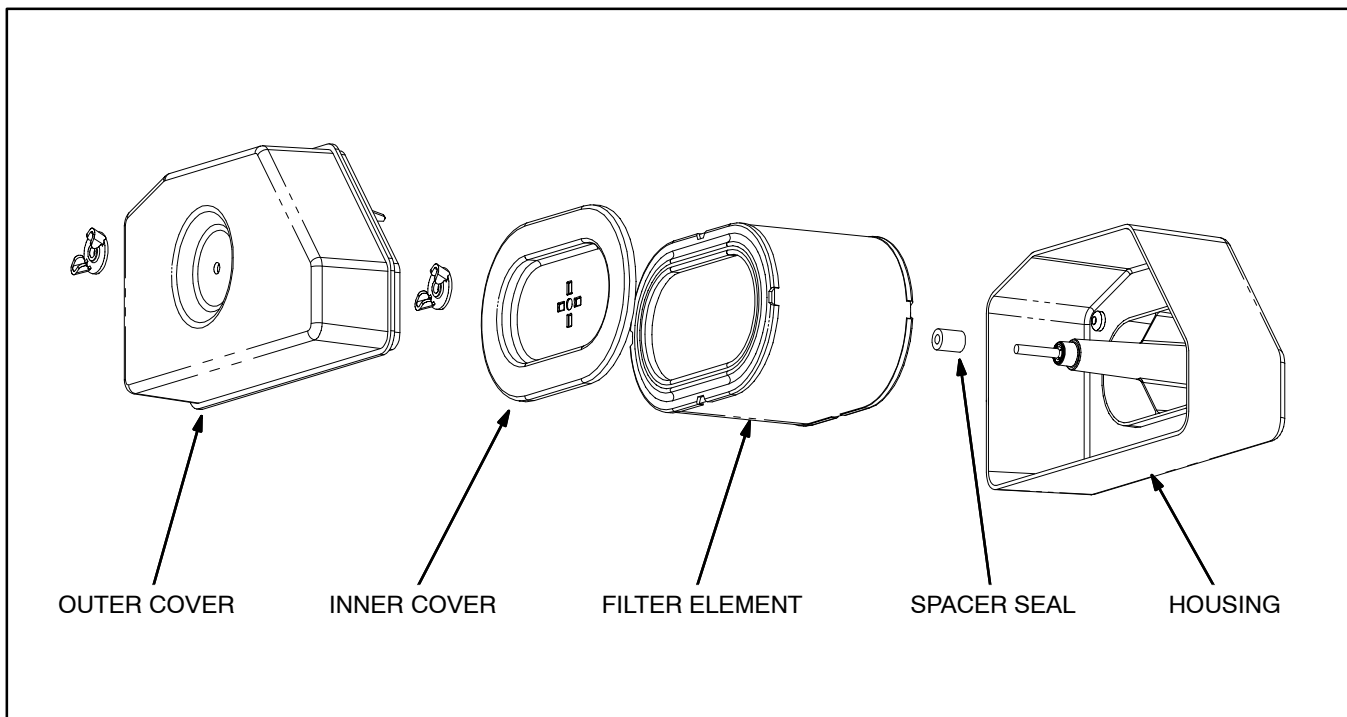

FIGURE 7. REPLACING THE AIR FILTER ELEMENT

CLEANING THE SPARK ARRESTOR

Refer to Table 3 for scheduled cleaning of the spark arrestor muffler (which meets U.S. Forest Service requirements). Cleaning is required for maximum genset performance.

⚠WARNING *A hot muffler can cause severe burns. Let the muffler cool down before removing or installing the cleanout plug.*

The muffler is mounted inside the genset housing. The cleanout plug is located on the side of the muf-

fler, accessible through the air outlet opening in the bottom of the genset. Clean out the spark arrestor muffler as follows:

1. Remove the cleanout plug from the muffler (Figure 8).
2. Restart the genset and load it nearly to full power. See **LOADING THE GENSET** (Page 9). Let the genset run for about five minutes to expel the soot in the muffler.
3. Stop the genset, allow the muffler to cool down and then reinstall the plug.

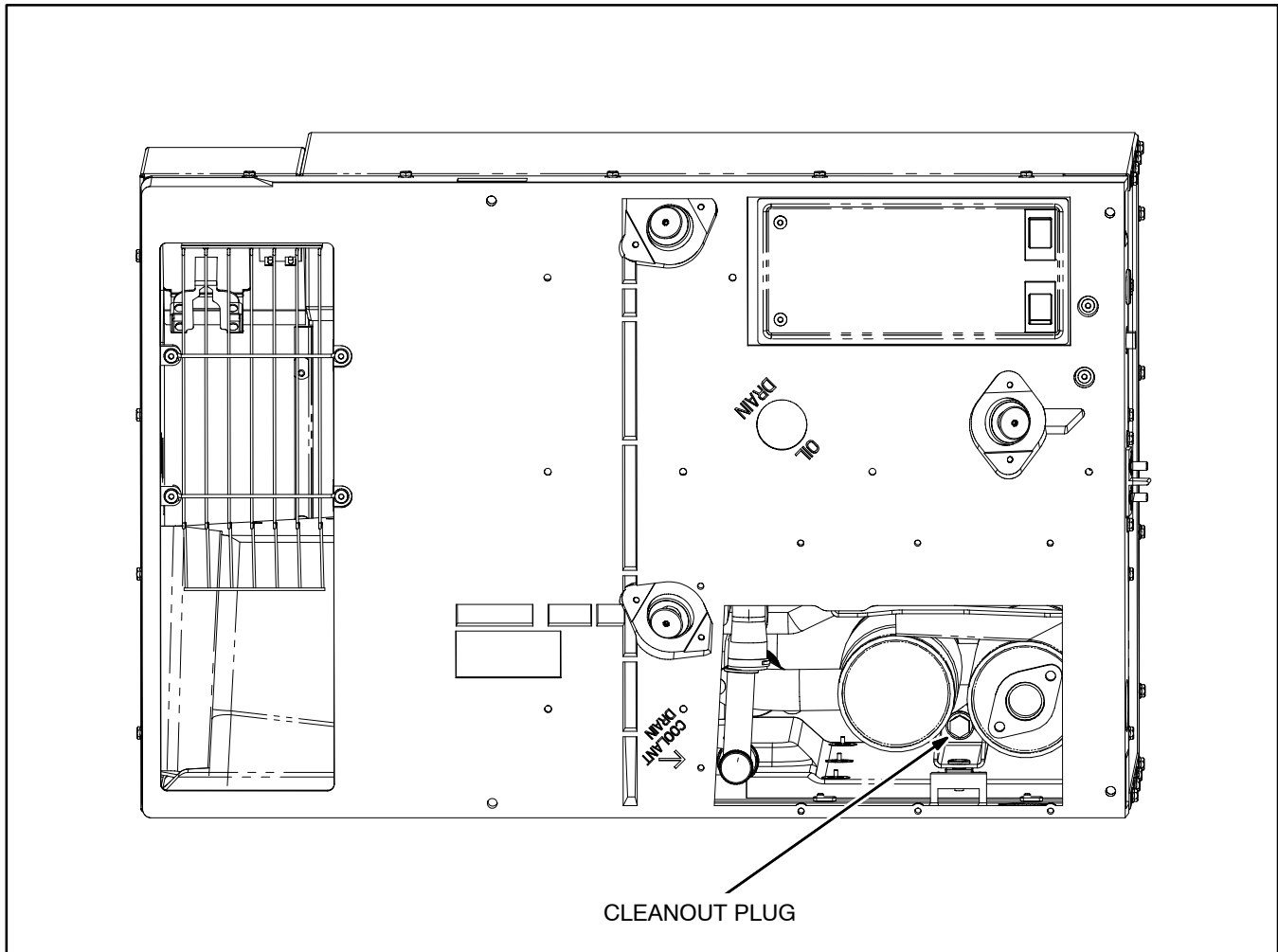

FIGURE 8. SPARK ARRESTOR CLEANOUT PLUG

REPLACING THE FUEL FILTER

Refer to Table 3 for scheduled replacement of the fuel filter (Figure 9). A dirty fuel filter may be the cause if the engine fails to start. The fuel filter is accessible through the maintenance access door in the skid-base. Squeeze the latches together to open the door.

CAUTION *Wipe dirt off the fuel hose connections at the fuel filter before disconnecting the hoses so as to keep dirt out of the fuel system.*

WARNING *Diesel fuel is combustible and can cause severe personal injury or death. Do not smoke. Keep flames, sparks, pilot lights, electrical arcs, switches and arc-producing equipment and all other sources of ignition well away. Keep a type ABC fire extinguisher handy.*

Removing the Fuel Filter: To remove the filter, disconnect the two fittings at the filter and remove the mounting nut. Apply a wrench on the filter fitting as well as on the flare nut so as not to stress the fitting. Flare nut wrenches should be used on the flare nuts so as not to round the corners on the nuts. Dispose of the fuel filter according to local regulations.

Installing the Fuel Filter: Rotate the filter half a turn around its mounting stud if the fittings interfere with the bracket. It only fits properly one way.

Connect the fuel fittings before tightening the filter mounting nut. Take care not to crossthread the fuel fittings. Thread them in by hand and tighten one flat past seating.

Close the access door and prime the fuel system by holding the control switch down in its **Stop** position for at least 1 minute. Priming is necessary to displace the air in the new filter with fuel.

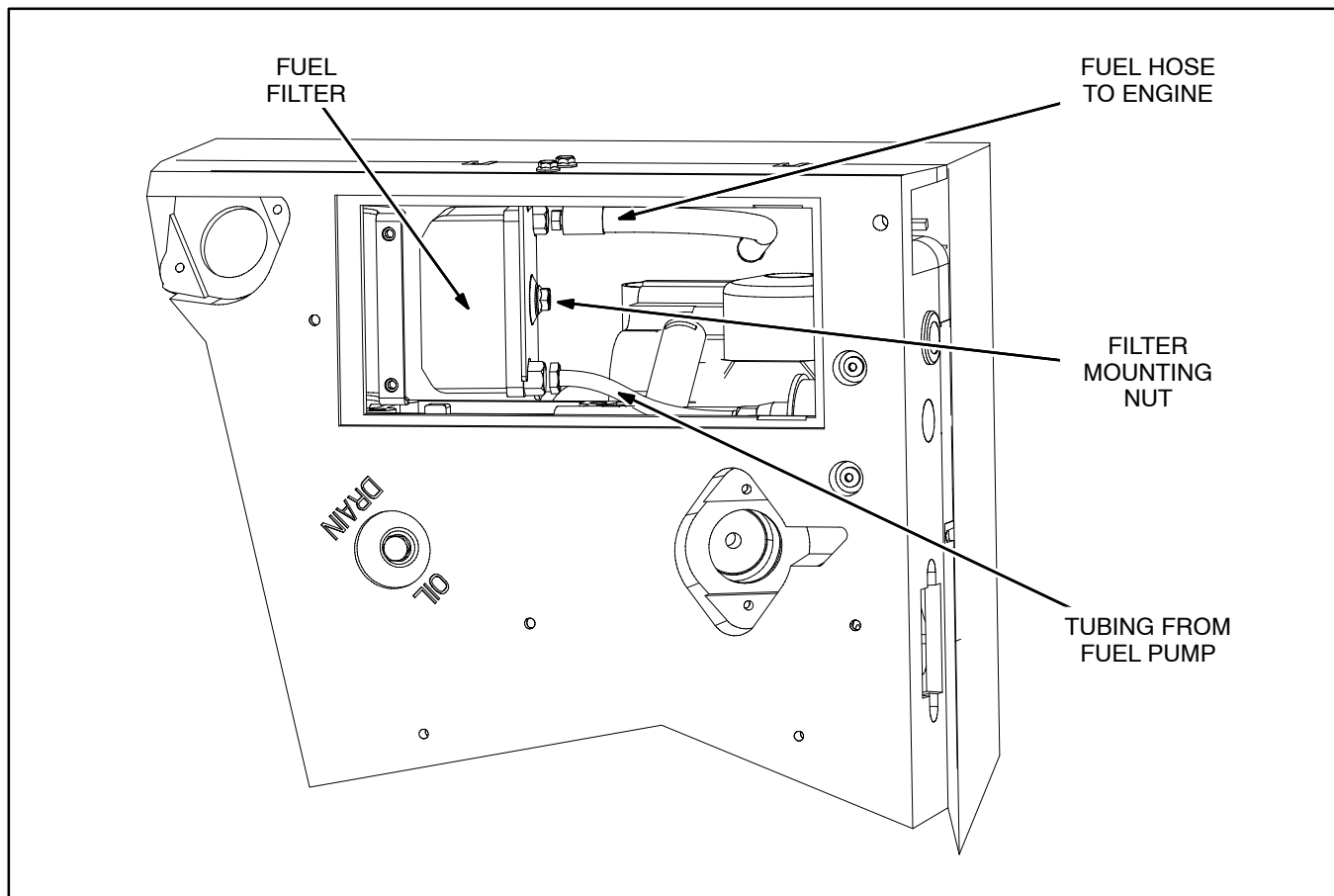

FIGURE 9. FUEL FILTER

CHANGING COOLANT

Refer to Table 3 for scheduled maintenance. The engine cooling system is filled with a 50/50 mixture of ethylene glycol anti-freeze and water when the genset leaves the factory, which is suitable for temperatures down to -34° F (-37° C).

Replace the coolant every two years. Use ethylene or propylene glycol anti-freeze solution that contains a rust and corrosion inhibitor. **The anti-freeze should not contain a stop-leak additive.**

The water used for engine coolant should be clean, low in minerals, and free of corrosive chemicals. Use distilled water if available. The cooling system has a 4.2 quart (4 l) capacity.

Pressure Cap

Replace the pressure cap (Figure 10) every two years because its seals can deteriorate and begin to leak. Proper cooling system pressure (14 psi) is essential for optimal engine cooling and minimal coolant loss.

Draining the Cooling System

⚠WARNING *Hot coolant spray can cause severe burns. Let the engine cool before releasing the pressure cap or removing the drain cap.*

Allow the engine to cool before removing the pressure cap. Then relieve any remaining pressure by turning the pressure cap slowly, without pushing down on it, until it catches. When the pressure has been relieved, remove the pressure cap by pushing

down and turning it until it can be withdrawn. Then get a suitable container and drain the coolant by removing the system drain cap (Figure 10).

⚠WARNING *Ethylene glycol antifreeze is considered toxic. Dispose of it according to local regulations for hazardous substances.*

It is recommended that the system be cleaned and flushed before refilling. Radiator cleaning chemicals are available at local auto parts stores. Follow the instructions for cleaning and flushing that come with the cleaning solution.

Refilling the Cooling System

Fill the recovery tank with coolant mixture to the COLD mark.

Secure the system drain cap. Fill the cooling system with coolant mixture through the pressure cap/fill opening. Pull the hose connected to the pressure cap assembly out as far as it will go. When coolant fills up to the fill opening, start and operate the genset for a few minutes and shut it down. (It is recommended that the air conditioners or other large loads be turned on so that the genset will operate under load, causing the engine to run faster and expel trapped air.) Add more coolant if necessary and secure the pressure cap.

Coolant Level Check

Check coolant level in the recovery tank (Figure 10) before the first startup of each day and fill to the COLD mark if necessary.

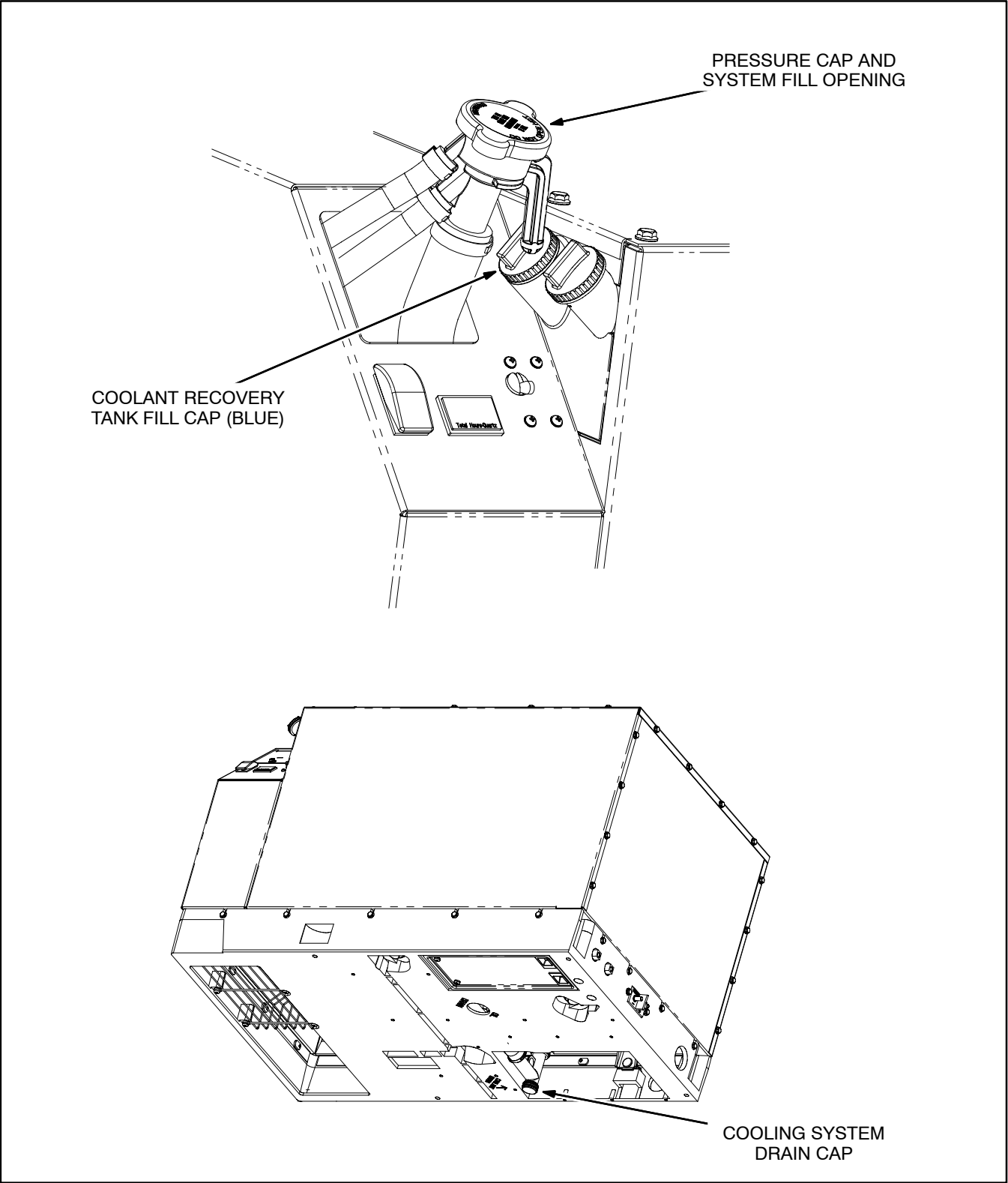

FIGURE 10. ENGINE COOLING SYSTEM FILL AND DRAIN CAPS

Troubleshooting

⚠WARNING *Hot engine parts can cause severe burns. Always allow the engine time to cool before performing any maintenance or service.*

TABLE 4. TROUBLESHOOTING lists the Fault Codes in numerical order along with step-by-step instructions for corrective action. If you fail to resolve the problem after taking the corrective actions suggested, contact an authorized Onan dealer. See *How to Obtain Service* (Page 33).

First note the following:

- Maintaining engine oil level, keeping battery connections clean and tight, watching the fuel gauge, not overloading the genset, etc. will prevent most shutdowns.
- When the genset and vehicle engine share a common fuel tank the fuel dip tubes are usually arranged so that the genset will run out of fuel first. Marking the genset empty point on the fuel gauge will make it easier to tell when to stop the genset before running it out of fuel.

First-Level Fault Codes: The genset controller provides extensive diagnostics by causing the status indicator light on the Control Switch to blink in a coded fashion. Following a fault shutdown, the indicator light will repeatedly blink 1, 2 or 3 blinks at a time.

- **One blink** indicates shut down due to high temperature

- **Two blinks** indicates shutdown due to a loss of engine oil pressure
- **Three blinks** indicates shutdown due to some other abnormal condition.

Second-Level Fault Codes: For a 1-blink or 3-blink first-level fault code, one touch to **Stop** brings up a second-level fault code. This code consists of 1, 2, 3 or 4 blinks, a brief pause, and then 1 to 9 blinks. The first set of blinks represents the tens digit and the second set of blinks the units digit of the fault code number. For example, Fault Code **No. 23** would appear as:

blink-blink—*pause*—blink-blink-blink—...

NOTE: Fault Code Nos. 1, 2 and 3 are first-level faults. Avoid interpreting them as second-level Fault Codes 11, 22 and 33. The pauses between repetitions of the fault code are longer than the pauses between the tens and units digits of the the code. For example, Fault Code 33 would appear as:

blink-blink-blink—*pause*—blink-blink-blink
—*longer pause*—
blink-blink-blink—*pause*—blink-blink-blink—...

Restoring Fault Code Blinking: The fault code stops blinking after five minutes. Press **Stop** three times within five seconds to restore blinking. Note that **the last fault logged will blink**, even after the condition that caused the shutdown has been corrected.

TABLE 4. TROUBLESHOOTING

⚠ WARNING *Some genset service procedures present hazards that can result in severe personal injury or death. Only qualified service personnel with knowledge of fuels, electricity, and machinery hazards should perform genset service. See Safety Precautions.*

GENSET WON'T STOP RUNNING—STATUS INDICATOR LIGHT ON

(Faulty Stop Switch or grounded wiring)

⚠ WARNING *Removing genset panels or disconnecting fuel lines to stop a genset that won't stop can lead to severe personal injury or death from electrocution, contact with moving parts or fire. Try the genset Stop Switch if the remote Stop Switch does not work, and vice versa. Otherwise, let the genset run out of fuel.*

GENSET WON'T STOP RUNNING—STATUS INDICATOR LIGHT OFF

(Binding governor mechanism, misadjusted speed stop)

⚠ WARNING *Removing genset panels or disconnecting fuel lines to stop a genset that won't stop can lead to severe personal injury or death from electrocution, contact with moving parts or fire. Let the genset run out of fuel.*

STATUS INDICATOR LIGHT STAYS ON

(Reversed battery connections)

Corrective Action: Reconnect the battery correctly (Page 17).

ENGINE CRANKS WHEN BATTERY CONNECTED

(Faulty Start Switch or grounded wiring)

Corrective Action: See an authorized Onan dealer.

ENGINE WON'T CRANK—FUEL PUMP WON'T STOP

(Faulty Stop Switch or grounded wiring)

Corrective Action: See an authorized Onan dealer.

STATUS INDICATOR LIGHT DEAD

(Faulty connections, no battery voltage)

Corrective Action:

1. Try the genset Start Switch if the remote Start Switch does not work, and vice versa.
2. Replace **Fuse F1** (B+) if blown (Page 7).
3. Clean and tighten the positive (+) and negative (-) battery cable connections at the battery, vehicle frame and genset (Page 17).
4. Recharge or replace the battery. Refer to the battery manufacturer's recommendations.

TABLE 4. TROUBLESHOOTING (CONT.)

⚠ WARNING *Some genset service procedures present hazards that can result in severe personal injury or death. Only qualified service personnel with knowledge of fuels, electricity, and machinery hazards should perform genset service. See Safety Precautions.*

STARTING BATTERIES RUN DOWN

(Marginal battery, battery connections, or charging system; or parasitic loads)

Corrective Action:

1. Clean and tighten the positive (+) and negative (–) battery cable connections at the battery, vehicle frame and genset (Page 17).
2. Recharge or replace the battery. Refer to the battery manufacturer’s recommendations.

ENGINE CRANKS BUT DOES NOT START

(Fuel delivery, glow plugs or engine are marginal)

Corrective Action:

1. Check fuel level. (Note: The genset fuel pickup is probably higher than the vehicle engine pickup.)
2. Prime the engine fuel system by holding the control switch down in its **Stop** position for at least 1 minute.
3. Check the engine air filter and remove any blockage (Page 17).
4. Replace **Fuse F3** (glow plugs) if blown (Page 7).

STARTER ENGAGES-DISENGAGES

(Cranking voltage dips below 6 volts—low battery charge, poor connections, long cables)

Corrective Action:

1. Have the vehicle propulsion engine running while trying to start the genset—the battery charging alternator may be able to maintain starting voltage high enough to get the genset started.
2. Clean and tighten the positive (+) and negative (–) battery cable connections at the battery, vehicle frame and genset (Page 17).
3. Recharge or replace the battery. Refer to the battery manufacturer’s recommendations.
4. Increase battery cable size or run parallel cables.

NO POWER—GENSET RUNNING, RUN LIGHT ON

(Line circuit breaker OFF or tripped or faulty wiring)

Corrective Action: Reset or turn “On” the line circuit breaker on the genset operator’s console.

GENSET HUNTS UNDER FULL LOAD

(Fuel delivery marginal, governor misadjusted)

Corrective Action: Prime the engine fuel system by holding the control switch down in its **Stop** position for at least 1 minute.

TABLE 4. TROUBLESHOOTING (CONT.)

⚠ WARNING *Some genset service procedures present hazards that can result in severe personal injury or death. Only qualified service personnel with knowledge of fuels, electricity, and machinery hazards should perform genset service. See Safety Precautions.*

HIGH TEMPERATURE—FAULT CODE NO. 1

(Engine coolant or inverter heat sink temperature exceeded design limit)

Corrective Action: Check the second-level fault code by touching Stop. The second-level fault will be either No. 33 or No. 34.

LOW OIL PRESSURE—FAULT CODE NO. 2

(Low oil pressure cutoff switch did not open)

Corrective Action:

1. Check engine oil level and add oil as necessary (Page 15).
2. Drain excess oil (above dipstick Full mark).

SERVICE CHECK FAULT—CODE NO. 3

(A second-level fault occurred)

Corrective Action: Check the second-level fault code by touching Stop. The second-level fault will be one of the following in this table.

OVERCURRENT FAULT—CODE NO. 11

(AC output short)

Corrective Action:

1. Turn off the genset line circuit breaker. If the genset no longer shuts down, the genset is probably okay—check for and repair a short circuit in the vehicle appliances, wiring or shorted battery charger transformer.
2. Check whether the vehicle engine and genset share the same starting battery. If so, and this fault occurs when cranking the vehicle engine, low battery voltage may be causing this shutdown. Increase battery capacity or install a separate battery and battery charging system for the genset.

INVERTER OVERVOLTAGE FAULT—CODE NO. 12

(Controller not able to regulate to rated voltage)

Corrective Action: Check whether the vehicle engine and genset share the same starting battery. If so, and this fault occurs when cranking the vehicle engine, low battery voltage may be causing this shutdown. Increase battery capacity or install a separate battery and battery charging system for the genset.

TABLE 4. TROUBLESHOOTING (CONT.)

⚠ WARNING *Some genset service procedures present hazards that can result in severe personal injury or death. Only qualified service personnel with knowledge of fuels, electricity, and machinery hazards should perform genset service. See Safety Precautions.*

INVERTER UNDERVOLTAGE FAULT—CODE NO. 13

(Controller not able to regulate to rated voltage)

Corrective Action: Check whether the vehicle engine and genset share the same starting battery. If so, and this fault occurs when cranking the vehicle engine, low battery voltage may be causing this shutdown. Increase battery capacity or install a separate battery and battery charging system for the genset.

INVERTER OVERFREQUENCY FAULT—CODE NO. 14

(Controller not able to regulate to rated frequency)

Corrective Action: Reduce the number of connected appliances, especially when air conditioners and battery chargers are running.

INVERTER UNDERFREQUENCY FAULT—CODE NO. 15

(Controller not able to regulate to rated frequency)

Corrective Action:

1. Reduce the number of connected appliances, especially when air conditioners and battery chargers are running.
2. Have air conditioners and other appliances checked for proper operation. (A locked compressor rotor can cause very low power factor.)

GOVERNOR ACTUATOR FAULT—CODE NO. 19

(Controller sensed open or short circuit)

Corrective Action: See an authorized Onan dealer.

GOVERNOR ACTUATOR OVERLOAD FAULT—CODE NO. 22

(Duration of operation at or near full-duty cycle beyond design limit)

Corrective Action: Reduce the number of connected appliances, especially when air conditioners and battery chargers are running.

LOW OIL PRESSURE CUTOFF SWITCH FAULT—CODE NO. 23

(Controller sensed switch still open during start—not a running fault)

Corrective Action: See an authorized Onan dealer.

TABLE 4. TROUBLESHOOTING (CONT.)

⚠ WARNING *Some genset service procedures present hazards that can result in severe personal injury or death. Only qualified service personnel with knowledge of fuels, electricity, and machinery hazards should perform genset service. See Safety Precautions.*

COOLANT TEMPERATURE SENDER FAULT—CODE NO. 24

(Controller did not sense temperature change during first 5 minutes of operation)

Corrective Action: See an authorized Onan dealer.

ENGINE ABOVE SPEED TARGET FAULT—CODE NO. 25

(Governor unable to regulate to target speed)

Corrective Action: See an authorized Onan dealer.

ENGINE BELOW SPEED TARGET FAULT—CODE NO. 26

(Governor unable to regulate to target speed)

Corrective Action:

1. Reduce the number of connected appliances, especially when air conditioners and battery chargers are running.
2. Prime the engine fuel system by holding the control switch down in its **Stop** position for at least 1 minute.

PMA SENSE LOST FAULT—CODE NO. 27

(Controller unable to sense PMA frequency)

Corrective Action: See an authorized Onan dealer.

DC SENSE LOST FAULT—CODE NO. 28

(Controller unable to sense DC bus voltage)

Corrective Action: Open the circuit breaker. If the fault does not persist, check for and disconnect excessive loads from the genset before starting.

HIGH BATTERY VOLTAGE FAULT—CODE NO. 29

(Voltage across battery system greater than 17.5 volts)

Corrective Action:

1. Check battery bank connections and reconnect if necessary so that the 12 volt batteries serving the genset are connected in parallel (12 volt) rather than in series (24 volt).
2. Select a lower battery booster charge rate.

TABLE 4. TROUBLESHOOTING (CONT.)

⚠ WARNING *Some genset service procedures present hazards that can result in severe personal injury or death. Only qualified service personnel with knowledge of fuels, electricity, and machinery hazards should perform genset service. See Safety Precautions.*

OVERSPEED FAULT—CODE NO. 31

(Engine speed greater than 3600 rpm)

Corrective Action: See an authorized Onan dealer.

LOW CRANKING SPEED FAULT—CODE NO. 32

(Cranking speed less than 180 rpm for more than 2 seconds)

Corrective Action:

1. Replace **Fuse F2** (starter solenoid) if blown (Page 7).
2. Clean and tighten the positive (+) and negative (–) battery cable connections at the battery and at the genset (Page 17).
3. Recharge or replace the battery. Refer to the battery manufacturer's recommendations.
4. Replace the engine oil with oil of proper viscosity for the ambient temperature (Page 16). (High oil viscosity can slow cranking speed.)

HIGH ENGINE COOLANT TEMPERATURE FAULT—CODE NO. 33

(Engine coolant temperature exceeded design limit)

Corrective Action:

1. Check the engine coolant level and add coolant and repair leaks as necessary (Page 20).
2. Check for and remove any objects blocking the air inlet or outlet openings in the bottom of the genset.
3. Reduce the number of appliances connected at the same time. (Note that high altitude and high ambient temperature decrease engine cooling capacity.)
4. Clean and flush the cooling system to remove coolant passage fouling.
5. If the genset overheats only underway, see the coach manufacture regarding air baffles or other means to direct cooling air into the genset.

HIGH INVERTER TEMPERATURE FAULT—CODE NO. 34

(Inverter heat sink temperature exceeded design limit*)

Corrective Action:

1. Check for and remove any objects blocking the air inlet or outlet openings in the bottom of the genset.
2. Reduce the number of appliances connected at the same time. (Note that high altitude and high ambient temperature decrease cooling capacity.)

CONTROL CARD FAILURE FAULT—CODE NO. 35

(Microprocessor EEPROM error during self-test)

Corrective Action: See an authorized Onan dealer.

TABLE 4. TROUBLESHOOTING (CONT.)

⚠ WARNING *Some genset service procedures present hazards that can result in severe personal injury or death. Only qualified service personnel with knowledge of fuels, electricity, and machinery hazards should perform genset service. See Safety Precautions.*

ENGINE STOPPED FAULT—CODE NO. 36

(Engine stopped without command by controller)

Corrective Action:

1. Check fuel level. (Note: The genset fuel pickup is probably higher than the vehicle engine pickup.)
2. Prime the engine fuel system by holding the control switch down in its **Stop** position for at least 1 minute.
3. Check the engine air filter and remove any blockage (Page 17).
4. Check for mechanical damage.

INVALID GENSET CONFIGURATION FAULT—CODE NO. 37

(Genset configuration is preprogrammed at the factory)

Corrective Action: See an authorized Onan dealer.

OVERCURRENT FAULT—CODE NO. 38

(Too many loads connected)

Corrective Action: Reduce the number of appliances running at the same time, especially those with high motor starting loads such as air conditioners. Start up with no load and let the genset run for five minutes to cool down the inverter.

PROCESSOR FAULT—CODE NO. 42

(Microprocessor ROM error during self-test)

Corrective Action: See an authorized Onan dealer.

TABLE 4. TROUBLESHOOTING (CONT.)

⚠ WARNING *Some genset service procedures present hazards that can result in severe personal injury or death. Only qualified service personnel with knowledge of fuels, electricity, and machinery hazards should perform genset service. See Safety Precautions.*

PROCESSOR FAULT—CODE NO. 43

((Microprocessor RAM error during self-test))

Corrective Action: See an authorized Onan dealer.

INVERTER POWER SUPPLY FAULT—CODE NO. 46

(Low battery voltage or power supply device failure)

Corrective Action:

1. Avoid running the genset while cranking the vehicle engine in installations where the genset batteries are used to supplement the vehicle engine batteries.
2. Clean and tighten the positive (+) and negative (–) battery cable connections at the battery, vehicle frame and genset (Page 17).
3. Recharge or replace the battery. Refer to the battery manufacturer's recommendations.
4. Install or service a battery charging system in the vehicle if the genset is not so equipped.

Specifications

	Model HDKAJ / HDKAT	Model HDKAK / HDKAU
GENSET CONTROLLER: Integrated Microprocessor Based Engine and Generator Controller		
GENERATOR: Brushless, Exciterless, Bearingless, Permanent Magnet Alternator		
AC OUTPUT RATINGS:		
Power (@1.0 power factor)	7500 W	8000 W
Voltage	120 volts	120 volts
Frequency	60 Hz	60 Hz
Number of Phases	1	1
Current	62.5 ampere	66.7 ampere
Line Circuit Breaker(s)	One 2-pole, 30 or 35 amp	One 2-pole, 30 or 35 amp
ENGINE: 3-Cylinder In-Line, Water-Cooled, Indirect-Injection, 4-Stroke Cycle Diesel		
Bore	2.64 inch (67 mm)	
Stroke	2.68 inch (68 mm)	
Displacement	44 inch ³ (719 cc)	
Compression Ratio	23 : 1	
Oil Capacity (with filter)*	3 quart (2.6 l)	
Cooling System Capacity**	4.2 quart (4 l)	
Intake and Exhaust Valve Lash (Cold)	0.0065 inch (0.165 mm)	
OPERATING SPEED RANGE:	1600 to 3200 RPM (HDKAJ) 2300 to 3200 RPM (HDKAT)	1600 to 3300 RPM 2300 to 3200 RPM (HDKAU)
FUEL CONSUMPTION:		
No-load	.13 gph (.49 l/h)	.13 gph (.49 l/h)
Half-load (4000 W)	.49 gph (1.85 l/h)	.49 gph (1.85 l/h)
Full-load	.96 gph (3.63 l/h)	1.02 gph (3.86 l/h)
DC SYSTEM:		
Nominal Battery Voltage	12 volts	
Minimum Battery Capacity	450 CCA*** down to 0° F (-17° C) 650 CCA*** down to -20° F (-29° C)	
Maximum Regulated-Voltage Battery Charging Current (Optional)	10 ampere	
Fuse F1 (control circuit)	10 ampere mini-bayonet	
Fuse F2 (starter solenoid circuit)	10 ampere mini-bayonet	
Fuse F3 (glow plug circuit)	25 ampere	
WEIGHT AND SIZE:		
Weight (wet)	420 lbs (191 kg)	
Length x Width x Height	36.3 x 23.6 x 22.3 inch (922 x 599 x 566 mm)	
* See oil filling instructions.		
** Includes coolant recovery tank.		
*** Cold Cranking Amps @ 0° F (-17° C)		

Information for California Genset Users

These gensets meet the requirements of California's Exhaust Emissions Standards as stated on the nameplate (Page 4).

As a California user of these gensets, please be aware that unauthorized modifications or replacement of fuel, exhaust, air intake, or speed control system components that affect engine emissions are prohibited. Unauthorized modification, removal or replacement of the genset label is prohibited.

You should carefully review Operator (Owner), Installation and other manuals and information you receive with your genset. If you are unsure that the installation, use, maintenance or service of your genset is authorized, you should seek assistance from an approved Onan dealer.

California genset users may use Table 5 as an aid in locating information related to the California Air Resources Board requirements for emissions control.

TABLE 5. EMISSIONS CONTROL INFORMATION

Genset Warranty Information	The California emissions control warranty statement is located in the same packet of information as this manual when the genset is shipped from the factory.
Engine Valve Clearance (Lash)	See <i>Specifications</i> (Page 31).
Engine Fuel Requirements	The engine is certified to operate on diesel fuel. See FUEL RECOMMENDATIONS (Page 6).
Engine Lubricating Oil Requirements	See ENGINE OIL RECOMMENDATIONS (Page 6).
Engine Adjustments	High Idle Speed. This is a service procedure requiring trained personnel and proper tools. See the Service Manual.
Engine Emission Control System	The engine emission control system consists of engine design and precision manufacture. (IFI)

How to Obtain Service

When you need parts or service for your genset contact the nearest authorized dealer or distributor. Onan has factory-trained representatives to handle your needs for genset parts and service. To locate the nearest authorized distributor:

1. Check the North American Sales and Service Directory (F-118) and the International Sales and Service Directory (IN-1013) supplied with your Onan genset. These directories list authorized distributors who will assist you in locating the nearest authorized dealer.
2. Consult the Yellow Pages. Typically, our distributors are listed under:
GENERATORS – ELECTRIC,
ENGINES – GASOLINE OR DIESEL, or
RECREATIONAL VEHICLES – EQUIPMENT,
PARTS AND SERVICE.
3. Call 1-800-888-ONAN for the name and telephone number of the nearest Onan dealer in the United States or Canada. (This automated service utilizes touch-tone phones only). By calling this number you can also request a di-

rectory of authorized RV servicing dealers: RV Sales and Service Directory F-919.

To get service, contact the authorized dealer or distributor nearest you, explain the problem and make an appointment. If you have difficulty in arranging for service or resolving a problem, please contact the dealer coordinator or service manager at the nearest Onan dealer for assistance.

Before calling for service, have the following information available:

1. *The complete genset model number and serial number. See Model Identification (Page 4).*
2. *The date of purchase*
3. *The nature of the problem. See Troubleshooting (Page 22).*

⚠️WARNING *Improper service or replacement of parts can result in severe personal injury, death, and/or equipment damage. Service personnel must be qualified to perform electrical and/or mechanical service.*



Cummins Power Generation
1400 73rd Avenue N.E.
Minneapolis, MN 55432
763-574-5000
Fax: 763-528-7229

Cummins and Onan are registered trademarks of Cummins Inc.